

LUBRICATE ALL SEALS WITH CLEAN HYDRAULIC OIL PRIOR TO ASSEMBLY.
DO NOT USE SILICONE BASED LUBRICANTS.

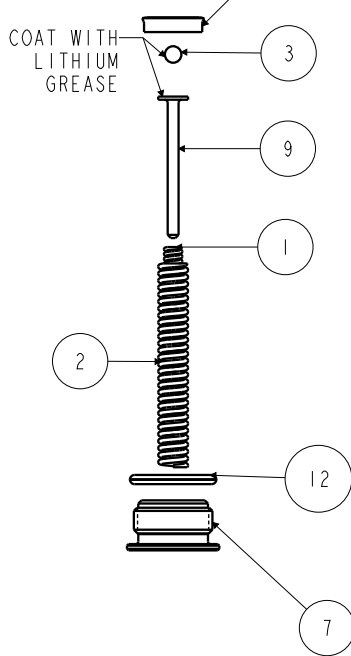

N/A	N/A	61250002	KIT, SPRING	N/A	N/A	NOTED
N/A	N/A	6V250111	KIT, SEAL, FKM	N/A	NOTED	N/A
N/A	N/A	60250111	KIT, SEAL, STANDARD	NOTED	N/A	N/A
12	1	39V00036	O-RING, (-908)	X	X	
11	1	39F54000	BU RING, (-111)	X	X	
10	1	91590001	ASSY, BREATHER, SAE 2			
9	1	81590501	ROD, SUPPORT, SPRING, SC, 450			
8	1	81510500	PLUNGER, SC, 450			
7	1	81400028	RETAINER, SC, HS, 450			
6	1	39053004	WIPER, SNAP-IN, (7/16)	X	X	
5	1	39010038	SEAL, BEVEL, 7/16 x 3/32 x 5/8	X	39052014	
4	1	39010036	SEAL, BEVEL, 3/8 x 3/32 x 9/16	X	39052010	
3	1	23600014	BALL, STEEL, ALLOY, .156			X
2	1	23311017	SPRING, COMPRESSION			X
1	1	23310008	SPRING, COMPRESSION			X
No.	QTY	PART No.	DESCRIPTION	STANDARD SEAL KIT	FKM SEAL KIT	SPRING KIT

PARTS LIST

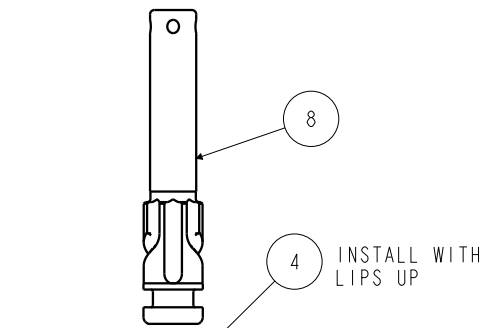
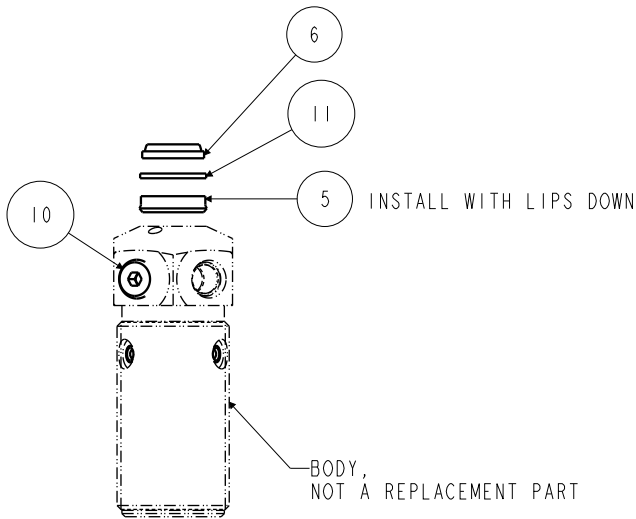

VEKTEK, INC.
1334 E. SIXTH AVE. P.O. BOX 625
EMPORIA, KS. 66801 U.S.A.

ASSEMBLIES AFFECTED
25010501
25010501F

PARTS LIST, ASSY, CYL, PULL, TB, 470

SIZE
A PL2527

REV
A

A	4573	RELEASE	RLK	12/17/21
REV	IN ACCORDANCE WITH ECN	EFFECTIVE DATE	REVISED BY	DATE
DRW BY:	RLK	DRAWING STATUS: Released		
DATE:	12/17/21	PRODUCTION APPROVED FOR RELEASED STATUS ONLY		